

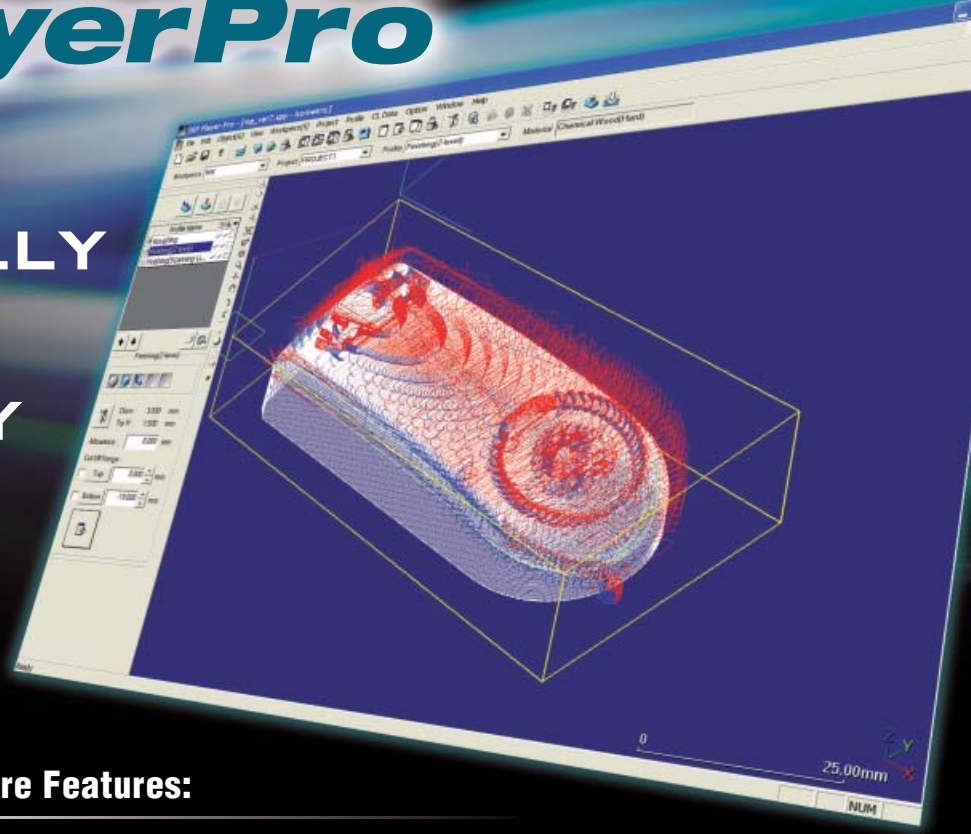

3D CAM Software for Roland Milling Machines

Player Pro

**EXCEPTIONALLY
PRECISE,
FINE QUALITY
MODELS**



Roland SRP Player Pro CAM Software Features:

- *Creates ultra-smooth surfaces and precise-fitting parts while optimizing cutter locations, also known as toolpaths*
- *Easy-to-use, wizard-style interface instantly sets the milling machine's parameters*
- *Creates models that inspire creativity and reflect all the details of the original data*

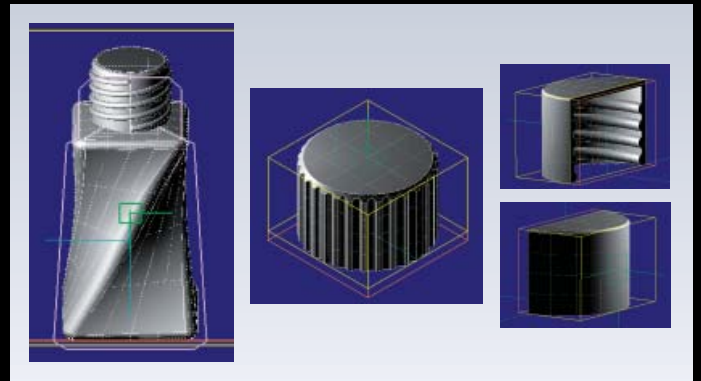
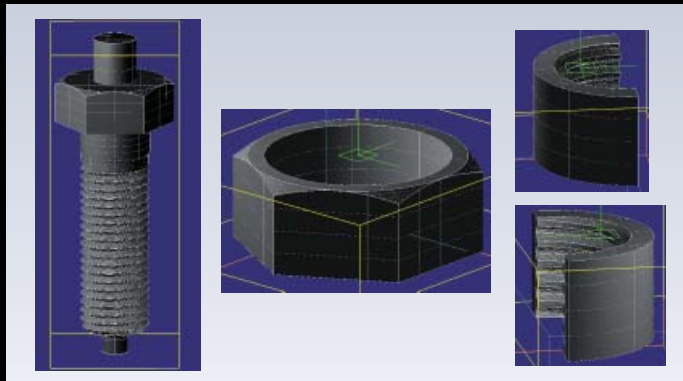

Check the precision of joined components such as this nut and bolt



Inspect the elegant curves, smoothness and overall design of a cosmetic bottle both visually as well as by touch

BEAUTIFULLY PRECISE OUTPUT

Unique method generates smooth, accurate cutter locations

SRP Player Pro ensures highly efficient milling, using CAD data to generate the cutter locations. It creates smooth surfaces directly from the original CAD data.

Unique SRP Player Pro Offset Method Produces Smooth Output

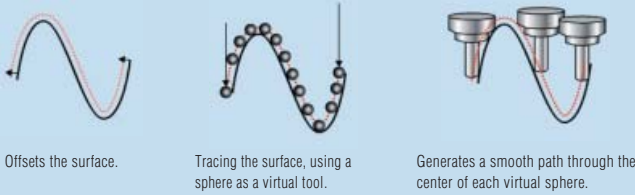

Polygon Calculation Method Produces Less Than Optimal Output

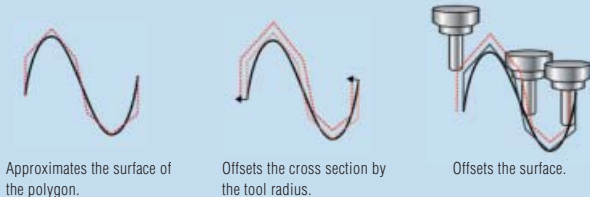

Selects cutting area to fit design

For greater operating efficiency, SRP Player Pro generates the right cutter locations for the targeted sections whether they are square, circular or polygon shaped.

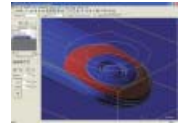

Optimizes cutter locations for finishing process

SRP Player Pro automatically generates the most efficient cutter locations for each of the different tools used. Larger radius tools are used to finish most of the surface area, while smaller tools are selected for fine details such as corners and indentations. This process ensures maximum throughput while maintaining the model's fine details and smooth surface.

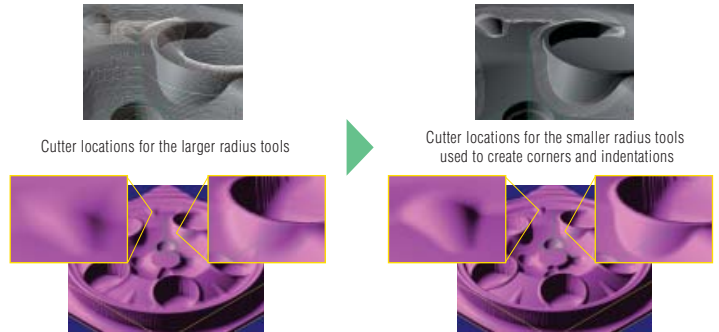

INTUITIVE WORKFLOW WITH EASY-TO-FOLLOW WIZARD

Simplify multifunctional CAM settings by following these steps to generate cutter locations

1ST STEP

Define work area

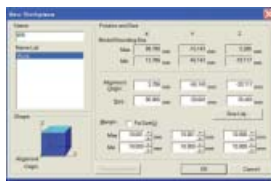

2ND STEP

Set up milling process parameters



3RD STEP

Generate cutter locations

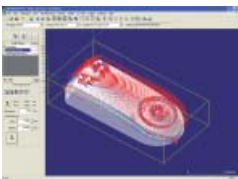

The Tool & Material database simplifies the set-up process for machine parameters such as feed speed and the number of revolutions per tool. It also registers new tools into the database.

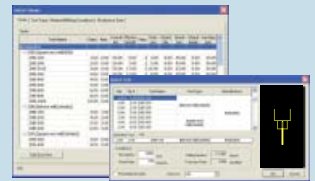

Database includes 42 types of tools
New tools can be added to the database



Database includes 25 types of material

Specifications

Import file format	Rhino File (Rhinoceros 1.0, 1.1, 2.0, 3.0, 4.0), DXF file (3D polygon mesh data only), IGES file (Preferably IGES V5.1 converted by JAMA-IS), and STL file (Binary and ASCII formats)
Saving file format	SRP Player Pro format (.spp)
Output code	G-code (Compatible with FANUC G-Code with some exceptions), and RML-1 (Roland Machine Language)
NC Setting	ATC (Automatic Tool Changer), Rotary Axis unit

Roland SRP Player Pro System Requirements

Operating system	Windows Vista® Business (32-bit edition), Windows® XP Professional Service Pack 2 (32-bit edition)
CPU	Intel® Pentium® 4 or faster
RAM	1024 or more is recommended
Free hard-disk space	2GB or more (800MB or more for virtual storage)
Connectivity	USB Port required (for Hardware Security Key)
Compatible Roland 3D Milling Machine	MDX-540, MDX-540S, MDX-540A, MDX-540SA, MDX-40, MDX-20, MDX-15, MDX-650(Discontinued), MDX-500(Discontinued),
Others	Pointing device, CD-ROM drive

ISO 14001:2004 and ISO 9001:2000 Certified

Roland pursues both environmental protection and continuous quality improvement. Under the philosophy of preserving the environment and human health, Roland is actively working to abolish organic solvents in production, to reduce and recycle waste, to reduce power use, and to purchase recycled products. Roland constantly strives to provide the most highly reliable products available.



Roland reserves the right to make changes in specifications, materials or accessories without notice. Your actual output may vary. For optimum output quality, periodic maintenance to critical components may be required. Please contact your Roland dealer for details. No guarantee or warranty is implied other than expressly stated. Roland shall not be liable for any incidental or consequential damages, whether foreseeable or not, caused by defects in such products.

Three-dimensional shapes may be protected under copyright. Customers are responsible for observing laws and ordinances when scanning. All trademarks are the property of their respective owners.



AUTHORIZED DEALER:

Printed in Japan. RDG-416011899 '08 OCT. E-3 P-5

www.rolanddg.com